

• TECHNICAL SPECIFICATIONS

FEATURES	ISO WITH LIGHTING AND AIR BLOW
Overall Dimensions mm (W x D x H)	210 x 300 x 360
Gross Weight Kg - Net Weight Kg	5.0 - 4.2
Connection and Working Power	220V AC 50Hz - 12V
Consumption: electric and pneumatic at 2 BAR	0.2A - 7 l/min
Fuse	3.15A
Instruments to be assembled in the jaw	from \varnothing 15 to \varnothing 32 mm
Max. vertical stroke of the forearm	16 mm
Standard collet holding tools	from \varnothing 3 to \varnothing 2,5 mm
Reduced collet holding tools	from \varnothing 2,5 to \varnothing 2,1 mm

• REFERENCE TECHNICAL REGULATIONS AND TEST PROCEDURES

Any instrument is mass-manufactured by C.I.E. DENTAFARM in compliance with technical and safety rules in force, as provided for by the 89/392 EEC Community Directive on Machinery and it is provided with CE marking and CE Declaration of Conformity. Careful inspection and full routine testing are carried out singularly on each machine.

According to International regulations, this unit has been classified as AEE (electric and electronic device, whose correct operation depends on electric currents and electromagnetic fields) and as a consequence, at the end of its lifetime, it can not be treated as normal waste material but it must be disposed separately, complying with the Directive 2002/96/CE.

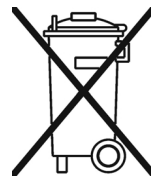

!! ATTENTION:

C.I.E. DENTAFARM is responsible only for risks deriving from purely mechanical devices, contemplating manual use, intended as components of the original configuration of the product.

Should a micromotor or a turbin be assembled, it is absolutely necessary to comply carefully with instructions, cautions and warnings of the Company manufacturing these instrument, above all referred to the eventual installation of protection shields, the adoption of suitable devices for individual protection, the use under safety conditions and the maintenance. We decline all responsibility also for tampering or improper use.

C.I.E. DENTAFARM Srl

Via Susa, 9/A - 10138 TORINO - ITALY

 TECHNICAL COMMERCIAL SERVICE - (+39) 011/4346588

 AFTER-SALE ASSISTANCE - (+39) 011/4346632

 FAX (+39) 011/ 4346366 – E-mail info@dentalfarm.it

Website: www.dentalfarm.it

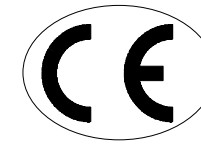

ISO SURVEYOR-PARALLELOMETER with lighting and air blow

 USE AND INSTRUCTION MANUAL

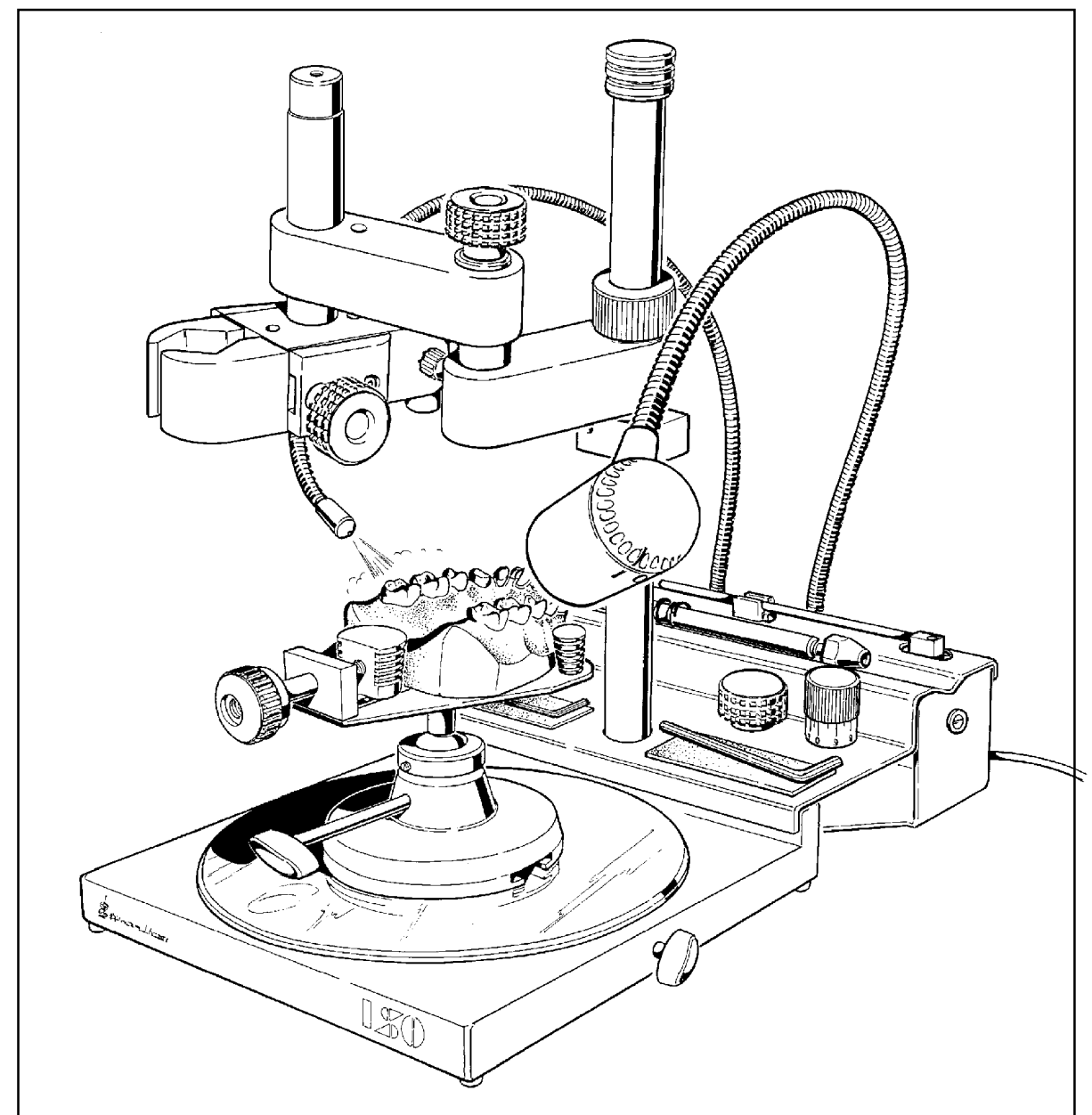

INDEX OF CONTENTS

INSTALLATION INSTRUCTIONS 3

GENERAL DESCRIPTION 3

DESCRIPTION OF STANDARD ACCESSORIES 3

TECHNICAL FEATURES 4

INSTRUCTIONS FOR USE 6

POSITIONING OF THE MODEL-HOLDER..... 6

WHEN POSITIONING THE ARM IN HEIGHT 6

WHEN POSITIONING THE ARM ON THE MODEL 7

USE OF THE GRADUATED KNOB..... 7

USE OF THE PARALLEL GUIDE ROD FOR CUTTING OPERATION..... 7

ASSEMBLY OF THE SPINDLE FOR MANUAL OPERATION..... 7

ASSEMBLY OF THE HANDPIECE FOR DRILLING OPERATION..... 8

ASSEMBLY OF THE GUIDE ROD FOR THE AXIAL SLIDING MOTION..... 8

TOOL STORAGE COMPARTMENT..... 9

MAINTENANCE INSTRUCTION 9

SPARE-PART LIST AND EXPLODED DRAWING..... 10

TECHNICAL SPECIFICATIONS..... 12

REFERENCE TECHNICAL REGULATIONS AND TEST PROCEDURES 12

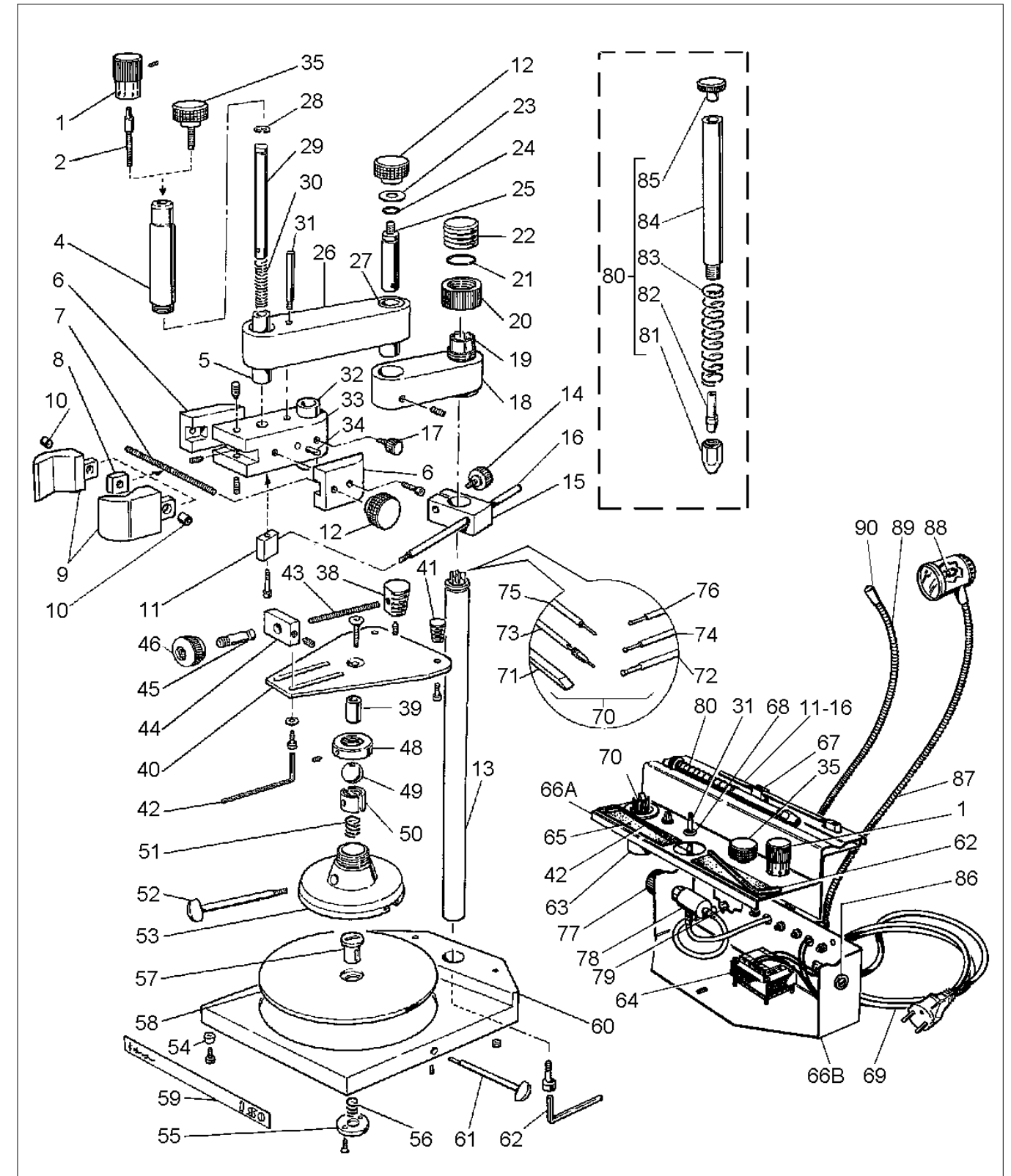

• SPARE-PART LIST AND EXPLODED DRAWING

N°	CODE	DESCRIPTION	N°	CODE	DESCRIPTION
1	NVT142	GRADUATED KNOB	54	NVG051	RUBBER FEET Ø 13
2	RI015	DEPTH ADJUSTING SCREW	55	RP054	LOWER CLOSURE
4	RI013	PROTECTION CASE	56	RC019	SPRING
5	RI016	BUSHING ON FOREARM	57	RP004N	MODEL-HOLDER LOCKING PIN
6	RI010	SIDE CLOSURE	58	RP003	WORKING TABLE
7	RI006	DOUBLE PITCH SCREW	59	RI049	ISO MARK LABEL
8	RI007	CENTRAL GUIDE	60	RP002	SURVEYOR BASE
9	RI004	JAW	61	RP510	MODEL-HOLDER LOCKING ROD
10	RI005	GUIDE FERRULE	62	NVT203	HEXAGONAL KEY NO. 6
11	RI037	LINKING LOOSE PIECE	63	RP053	TOOL SUPPORT BUSH
12	NVT147	Ø 30 M6 FEMALE KNOB	64	NES039	TRANSFORMER 220V-12V 6W
13	RP006A	STAINLESS STEEL COLUMN	65	RCB064	MAGNETIC BAND
14	NVT153	Ø 25 M6 X 25 MALE KNOB	66A	---	UPPER ELEMENT
15	RI035	HEIGHT ADJUSTING ELEMENT	66B	---	LOWER ELEMENT
16	RI036	GUIDE ROD FOR AXIAL SLIDING MOVE.	67	NEA109	PLASTIC CLIP
17	NVT151	Ø 15 M4 X 10 MALE KNOB	68	NEA112	PLASTIC BUSH
18	RI001	REAR HORIZONTAL AXLE	69	NEV010	FEEDING CABLE
19	RI019	BUSHING ON COLUMN	70	RP505	COMPLETE SET OF TOOLS
20	RI020	LOCKING RING NUT ON COLUMN	71	RP030	WAX TRIMMING TOOL
21	NPOR119	OR 119 RING	72	RP033	Ø 0,75 UNDERCUT GAUGE
22	RP007	COLUMN KNURLED TOP	73	NVV040	GRAPHITE PENCIL-HOLDER
23	RI009	SHOULDER WASHER	74	RP032	Ø 0,50 UNDERCUT GAUGE
24	NPOR112	OR 112	75	RP034	ANALYSING ROD
25	RI008	CENTRAL ROTATION AXLE	76	RP031	Ø 0,25 UNDERCUT GAUGE
26	RI002	REAR HORIZONTAL AXLE	77	NVT106	VALVE KNOB
27	RI018	BUSHING ON CENTRAL ARTIC. JOINT	78	RNO501	AIR VALVE
28	NVT039	SEEGER RS 8	79	NPR211	PIPE-FITTING FOR PNEUM. CONNECTION
29	RI011	REAR ROTATION AXLE	80	RP508	TOOL HOLDING ROD COMPLETE
30	RI012	REACTION SPRING	81	RP011	TOOL LOCKING NUT
31	RI028	DRILLING GUIDE	82	RP012	Ø 3,0 COLLET
32	RI017	BUSHING FOR TOOL HOLDER	---	RP040	Ø 2,5 COLLET
33	RI003	FOREARM	---	RP035	Ø 2,1 COLLET
34	NVT050	CYLINDER PIN	83	RP013	SPRING ON ROD
35	NVT148	Ø 30 MALE M6 X 25 KNOB	84	RP010	TOOL HOLDING ROD
38	RI021	MODEL LOCKING PIN	85	RP009	CAP
39	RP042	SPACER	86	NEA060	FUSE-HOLDER
40	---	MODEL-HOLDER PLATE	87	NEA026	FLEXIBLE LIGHTING SYSTEM
41	RI027	PLATE PUSH ROD	88	NEA028	HALOGEN LAMP 12V 6W
42	NVT201	HEXAGONAL KEY NO. 3	89	NEA027	AIR FLEXIBLE PLASTIC HOSE
43	RI023	THRUST SCREW	90	RI044	AIR BLOWER
44	RI024N	GUIDE SUPPORT			
45	RI022	GUIDE FOR SCREW			
46	RI042	FEMALE KNOB			
48	RP019	ADJUSTING RING NUT			
49	RP018	ARTICULATION BALL			
50	RP016	LOCKING CLAMP			
51	RP017	MODEL-HOLDER SPRING			
52	RP507	ARTICULATION LOCKING ROD			
53	---	MODEL-HOLDER BASE			
---	RP502	MODEL-HOLDER COMPLETE			

• INSTALLATION INSTRUCTIONS

To operate the precision surveyor/parallelometer, proceed as follows:

1. place the instrument on a perfectly flat and even working bench.
2. Plug in to an approved 220V - 50 Hz socket with ground connections and turn the lamp rear cap from position 0 to 1 to check functioning of the lamp.
3. Assemble the proper fitting to the pipe utilized for compressed air (choose the right one from the set supplied with the instrument) and check airtight sealing.

• GENERAL DESCRIPTION

The new SURVEYOR-PARALLEOLOMETER is made up of one mechanical holding arm for any handpiece or micromotor already owned by the Laboratory, which is mounted on the structure of the DENTALFARM surveyor, with the aim to allow, in addition to the traditional manual operation, to carry out accurate drilling operations, too.

With the new arm, you are allowed to execute the same manual operations usually carried out with the DENTALFARM surveyor, viz:

- to determine the path of insertion for the attachments
- to position the attachments
- layout of the reference points
- to survey the prosthesis
- to locate the anchorage positions of clasps.

The novelty is represented by the adoption of a universal holder for clamping, under condition of perfect orthogonality, any straight dental handpiece for the most sophisticated operations:

- drilling at calibrated depth
- boring
- screw thread
- parallel milling
- milling of anatomic abutment
- "coulisse" execution.

• DESCRIPTION OF STANDARD ACCESSORIES

The principal parts of the instruments are as follows:

- the support light alloy casting with stainless steel horizontal working plan;
- the storage compartment for tools;
- the model-holder for mechanical clamp;
- the upright holding column made of gauged and ground stainless steel;
- the element adjusting height of the arm on the column;
- the double-joint arm;
- the horizontal guide rod for the axial controlled sliding motion;
- the vertical guide rod for drilling operation;
- the graduated knob limiting and measuring the vertical stroke;
- the reciprocating knob locking the front articulated joint;
- the spindle for manual operation which is fitted with two collets of different diameter;
- the set of tools (stored in the hollow central column protected by a cap);
- the set screw wrench no. 3 and no. 6 used to assemble the parts.

• TECHNICAL FEATURES

Among the variety of applications of a Surveyor equipped with a Handpiece Holder identified as “milling operation”, we can split it up in two well defined groups according to the technique used:

1. when the model-holder is fixed on the base and the arm is operated,
2. when the arm is fixed and the model-holder is operated.

Basically, the structure of the machine will allow to opt for one of the two solutions. For the second option, high complex milling machines are required, equipped with model-holders assembled on micrometric feed saddle, contemplating a considerable investment not only in money but in time devoted to learning, too.

The DENTALFARM SURVEYOR-PARALLELOMETER allows to carry out those operations contemplated in point 1, with no obstacle to “free-hand” operation as provided for in point 2.

The arm can freely slide on the vertical axis of the holding column (1), if leaned on the height adjusting element (2), or alternatively be locked in any position by tightening the proper ring nut (3).

The (4 and 5) arm joints, which articulate on the vertical axis, move on ferrules and can be both frictioned and locked by means of the pertinent knobs.

Thanks to these three rotation points, any movement of the pantograph arm is thus possible, allowing a free and smooth traverse on the full working area.

The forearm (6) is the mobile rear component holding the spindle; the conceiving provides for the rotation fulcrum located at the centre offering the possibility to assemble on one end (17) the spindle for manual operations or, angulating it up to 180°, on the other end (18) the handpiece for drilling instruments.

The complete rear unit can freely slide on the vertical axis and it is fitted with spring recovery but in case of drillings, it is possible to limit the downstroke movement (depth measurement) and restrain the parallelism (the max. vertical stroke is 15 mm).

The supply of a tool, extremely easy to be mounted, guiding the movement of controlled axial sliding, has been contemplated, too.

Any SURVEYOR-PARALLELOMETER consists of a base for the models (7) which can freely slide or be fixed to the surface plate. A pin inserted in the base race securely locks the model table in place then fixed by the rod knob (8).

The model table has a central ball-articulated joint allowing for angulation in any direction up to 30° and to turn on itself for the whole circle; the table can be locked in any desired position simply by tightening the knob (9).

The model locking system offers a wide amplitude allowing to mount various shapes of models.

• TOOL STORAGE COMPARTMENT

On the upper shelf on the compartment, the following tools are conveniently located: the guide rod for axial sliding (20-21-22) and the spindle for manual operation (16); on the lower shelf we can find, starting from the left: the reference tools of the surveyor (70), the tool holder for collet of reduced diameter (24), the parallel guide rod for drilling (12), the male tightening knob (15), the graduated knob (13) and, on the two sectors covered by magnetic bands (25), the hexagonal clamping key wrench (23) and the eventual burs to be used.

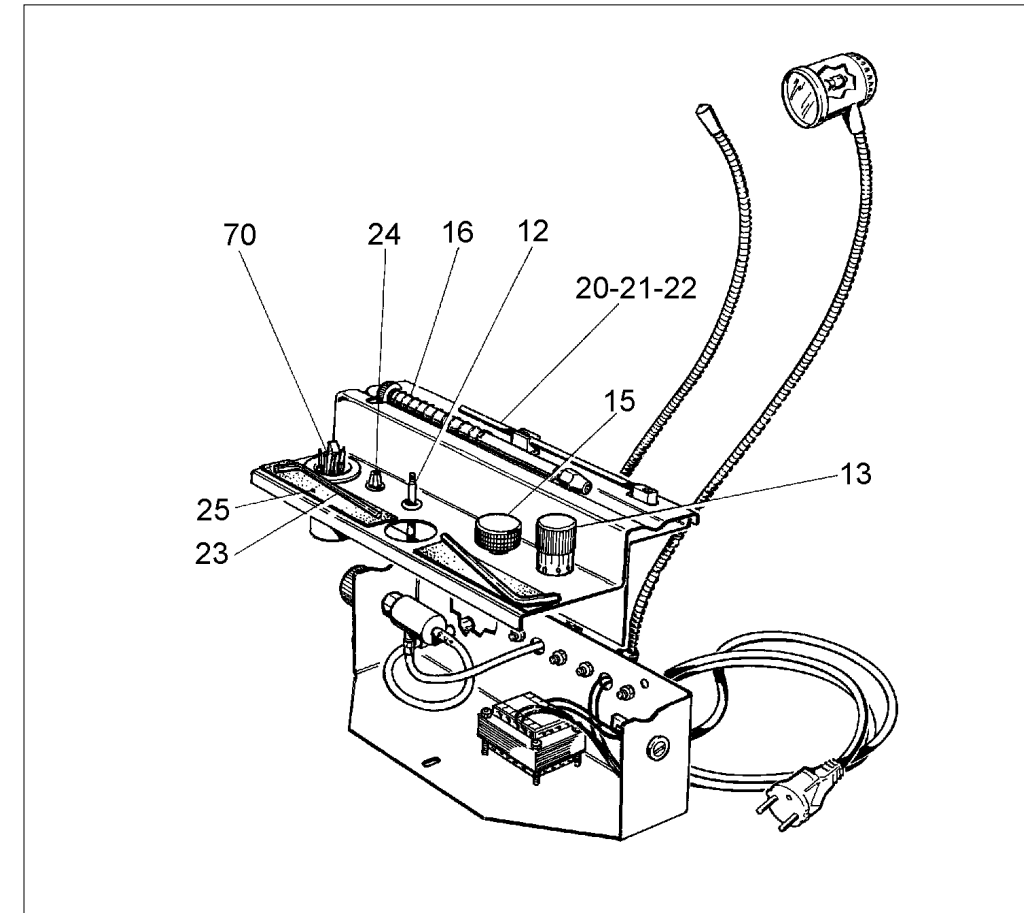

ILL. 8

• MAINTENANCE INSTRUCTION

To assure optimum performance of the instrument, it is indispensable to clean accurately any sliding components and lubricate them with acid free oils for turbine engines or pure vaseline, never blow with compressed air to prevent small dust particles from entering the bushes and the bearing.

It is also necessary to remove opportunely the chips and the dust microparticles in order to avoid any damages or scratches compromising the correct motion which, on the other end, has to be facilitated by specific antifriction products when you are working with the fixed arm and the movable model-holder.

Any single component can be dismantled by referring to the enclosed plan of the instrument printed at the end of the present manual allowing to understand correctly how the different parts have been assembled.

May we remind you to place the tools which are not being used in the storage compartment thus avoiding to loose or to damage them.

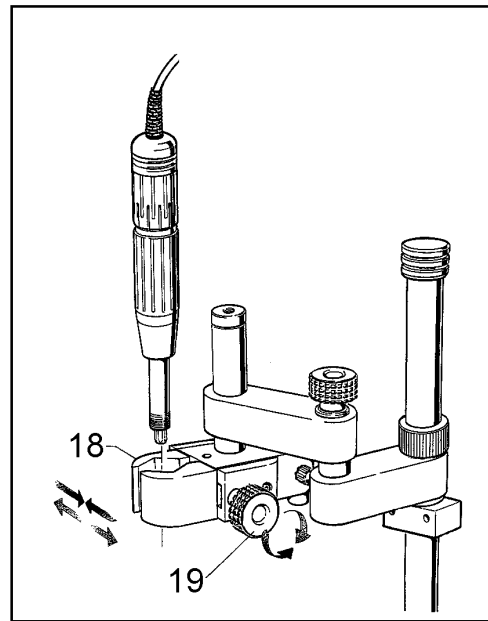

• **ASSEMBLY OF THE HANDPIECE FOR DRILLING OPERATION**

The handpiece or micromotor holder (18) has a range from diameter 15 mm to 32 mm allowing to clamp practically any instrument utilized in the dental field; despite this, our preference is given to those handpieces with perfect cylindrical shape and made of rigid material (in case the handpiece is rubber-coated for better grip, we suggest to remove this part).

To mount the handpiece, it is sufficient to open the holder (turn knob - 19 - rightward) until it is clamped, then tighten firmly.

When clamping the handpiece, be careful to find the nearest point to the bur holding pliers (according to the tool locking system).

ILL. 6

• **ASSEMBLY OF THE GUIDE ROD FOR THE AXIAL SLIDING MOTION**

This tool will be mounted from one side to height measuring gauge on the holding column and the other side on the forearm lower face, in correspondence with the central axle.

For the installation proceed as follows:

- introduce the free end of the guide rod (29) in the block (2);
- let free any hinge points, fold the arm in correspondence of the height of the rear articulated joint (right- or leftward as you are accustomed to) and align both the arm and the block;
- bring the other end (22) near the centre of the forearm articulated joint and tighten the screw (21) utilising the key no. 3 (23) supplied;
- when all the elements are correctly aligned, tighten definitively the block knob (2) and test sliding; if it is perfectly free, position the model-holder parallel to the sliding axle.

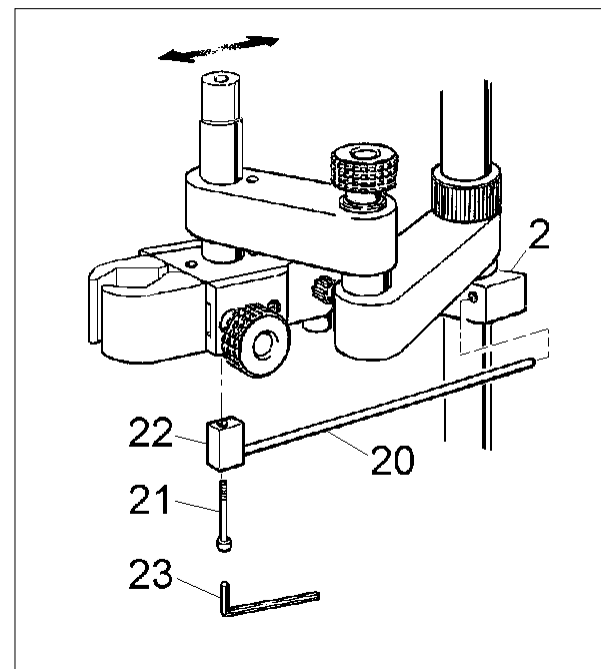

ILL. 7

When the tool is not used, it is necessary to disassemble it completely; to do this, simply loosen the screw and remove the guide rod; it is recommended to store it in a protected place in order to avoid any damage (scratch); for this purpose, the tool storage compartment embodies a rack for accessories.

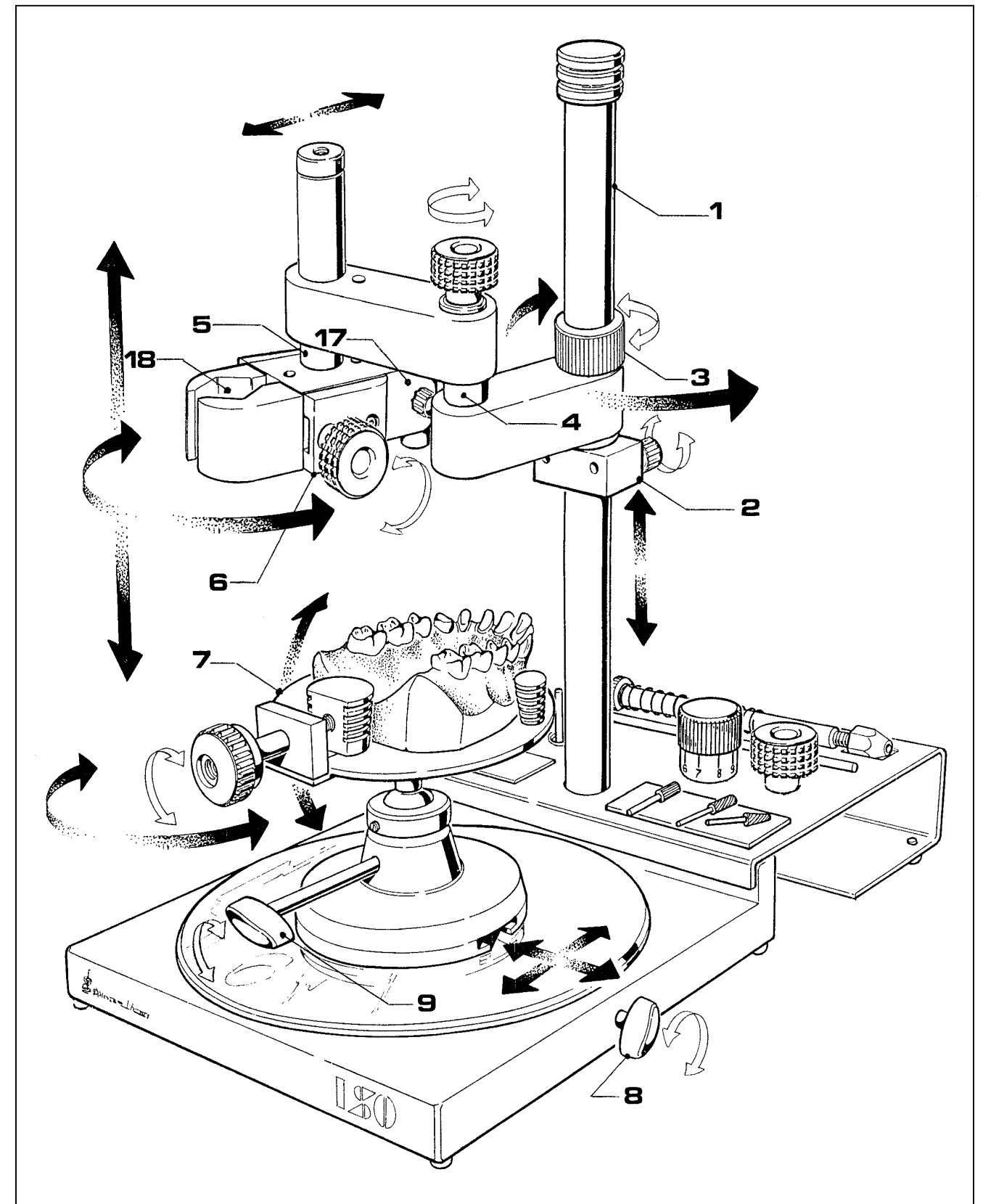

ILL. 1

• **INSTRUCTIONS FOR USE**

No doubt the drilling and milling technique used in the dental field cannot be summed up in a few lines, therefore in the following chapter illustrating the instructions for use, the various movements and limits of each component are clearly illustrated and detailed along with the useful hints which help you to solve the daily small inconveniences.

• **POSITIONING OF THE MODEL-HOLDER**

The model-holder can freely slide on the working plane or be locked in place according to different requirements. To lock it firmly, simply let the spring pin (turn the knob - 28) come out from the working plane, then introduce the longitudinal guide (27) of the model-holder and turn the same knob (28) rightwards.

If you are working with the model-holder locked in place, we recommend to tighten it the nearest possible to the central axis of the working plane in order to guarantee that even under stress no vibrations are originated.

The model-holder plate (29) is assembled on a ball (30), it can rotate up to 360° and it can be tilted up to a maximum of 30° allowing to restore the chewing conditions; the proper knob (31) must be accurately tightened to lock it firmly in place

If you need to have it in a position perfectly parallel to the working plane, it is sufficient to lean the lower face of the forearm on the plate itself, facilitate fitting and lock in place. The new model positioning system allows a wider stroke and a safer locking. When turning the knob (32) rightwards, the pressure element (33) recedes, whereas it goes forward if the knob is turned leftwards and it locks the model against the fixed push rods (34); for smaller pieces, it is possible to let the full locking system slide forward along the transverse slots (loosen the upper screws and close them in the new position).

Should you need to work with the free model-holder, you simply have to tighten the locking pin to the base, utilizing for that purpose a coin to lower the pin, turn it rightwards and fix it with the knob (see illustration 2 bis).

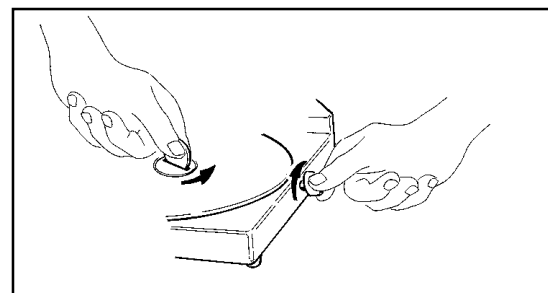

ILL. 2 bis

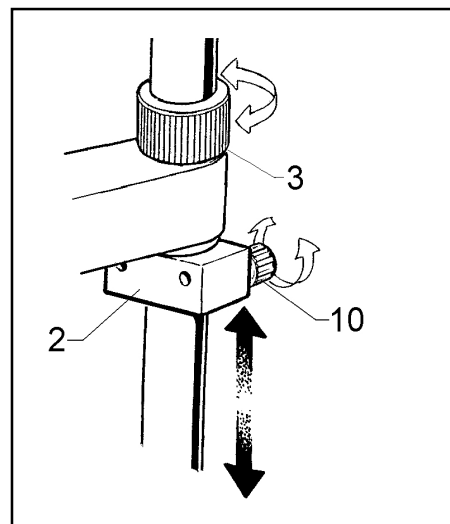

ILL. 3

• **WHEN POSITIONING THE ARM IN HEIGHT**

To position the arm in height, set the adjusting element (2) and the fixing ring nut (3). When both elements are loosened, let the unit slide on the column until the preset point is attained, then close the pressure knob (10). If the arm has to turn freely, this is the right working condition, whereas if it has to be locked in place, turn the ring nut (3), too (turn rightwards to lock, leftwards to open).

• **WHEN POSITIONING THE ARM ON THE MODEL**

As already mentioned in the introductory chapter, the arm is fitted with two additional intermediate joints facilitating the approach to the working point; they can be both fix or movable.

To lock the rear joint it is sufficient to tighten the knob (11 ill. 4) whereas for the front joint it always depends on the procedure to be carried out:

1. if you need to eliminate the possibility to slide vertically, assemble the tightening male knob (15 ill. 5) on the upper cap and screw tight,
2. if you wish to drill, thus maintaining the vertical movement but eliminating the others, assemble the parallel guide rod (12 ill. 4) in the upper movable part (in this case it is possible to insert the stroke limiting knob (13 ill. 4) on the upper cap functioning as both depth stop and as measuring gauge).

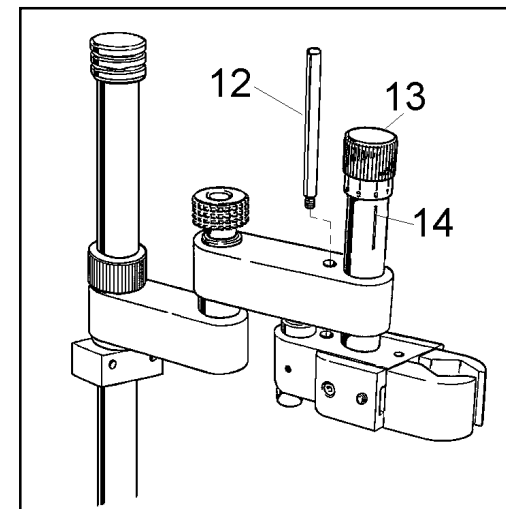

• **USE OF THE GRADUATED KNOB**

By screwing tight the graduated knob (13) in the upper cap, the forearm is only allowed to rotate but not to run down (optimum condition to execute parallel drillings with radial delimitation at the same height).

Glancing sideways at the black protection cylinder, you can notice a vertical reference line (14): when the knob is tight screwed, make the zero of the scale mate with this line; by unscrewing you will determine the depth amplitude let to the movement of the instrument (every figure corresponds to a tenth of millimetre, therefore every complete turn is equivalent to a millimetre of actual vertical sliding).

ILL. 4

• **USE OF THE PARALLEL GUIDE ROD FOR CUTTING OPERATION**

To assemble the parallel guide for cutting (12 ill. 4), it is necessary to align both the arm and the forearm and introduce the rod in the hole drilled behind the black protection cylinder until you find the insertion point and screw tight; in such a way the sliding will stiffen and side movements are inhibited.

• **ASSEMBLY OF THE SPINDLE FOR MANUAL OPERATION**

The spindle rod (16) is located on the movable forearm (17), in the hole opposite the pliers: for assembly simply unscrew the lower ring nut (26).

The tools are introduced in the pliers and fixed in place by means of the ring nut, the standard pliers embodied in the rod is Ø 3 where the supplied tools are clasped; for attachment holder having lower diameter, a smaller pliers is available. It is recommended to assemble on the rear joint the male tightening knob (15) allowing rotation with no possibility of downstroke when it is loose and it can lock any movement when positioning the attachments.

When it is not used, it is indispensable to remove it and store it in a safe place in order to avoid it limit the movements or touch unintentionally the model.

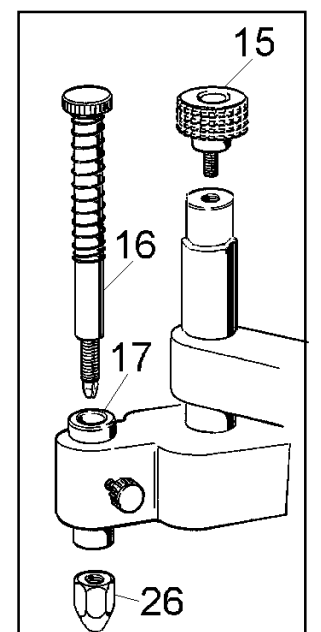

ILL. 5